

Redesign Powerbox

Industrial Electronics/ Prof. Dr. Andrea Vezzini / Dr. Elham Firouzi / Off-Grid Ltd. CH 7432 Zillis
Expert: Urs Muntwyler

As the need for mobility rises, so does the demand for alternative sources of energy. More and more digital nomads are roaming the far corners of the world – conducting research in remote regions, documenting expeditions to high alpine mountains or simply taking a new digital camera on a weekend trip to the Alps. This Bachelor thesis aims to significantly expand the application spectrum and user-friendliness of portable solar chargers through the innovative use of the latest technology.



Etienne de Coulon

The Task

Off-Grid GmbH, located in Zillis, Switzerland, develops and produces portable solar chargers with flexible thin-film solar modules. Their product range allows users to charge all types of devices from cellular phones to laptops. An energy storage cell, the Powerbox, serves as the interface between the solar modules and the end devices. The Powerbox uses the most efficient way to draw energy from the chosen source, stores it and makes it available to the end device in the desired voltage at all times.

This Bachelor thesis covers a complete technical redesign of the Powerbox for the Off-Grid SunbagL. The Powerbox specifications are as follows: energy storage capacity of around 50Wh, input power 2W to 20W, input voltage range 4V to 19V DC or AC, maximum output current 4.5A, output power available between 5V and 19V.



Christ Andri Hassler



Powerbox Sunbag L in use.

The Idea

By using a high-capacity digital signal processor from Texas Instruments (TMS320F28027) both boost converters and buck converters can be set and controlled separately. The programs Matlab, Simulink, Plecs and SPICE simulations were used to develop an algorithm that will charge the internal lithium-ion polymer battery using different sources of energy (e.g. solar modules or hub dynamos). An internal battery management system ensures the battery is consistently monitored and protected.

The software algorithm was also expanded to make it possible to interconnect two or more Powerboxes to cover higher capacity requirements. In this case the input energy is divided inversely proportionally to the charge level. At the output, the amount of power needed is determined and delivered proportionally to the charge level. The hardware design can be connected to both AC and DC sources. Furthermore, the Powerbox is protected from excessive voltage and currents.

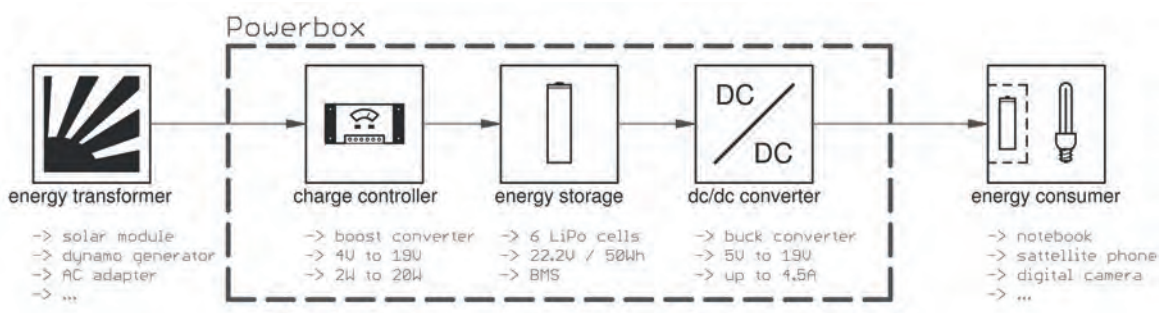

How the Powerbox works.